

PIONEER
WORLD-FAMOUS BRAND IN HI-FI REPRODUCTION

**PROFESSIONAL,
BELT DRIVE
STEREO TURNTABLE
PL-41A
PL-41C**

driven by any other system. The motor is of the hysteresis synchronous type, flawless and silent. The newly designed tonearm, cartridge, and hydraulic cueing device are products of PIONEER's precision engineering and advanced design.

To assure yourself that you are using this turntable to its fullest advantages, read this instruction manual now and keep it as a handy reference.

(FV)

OPERATING INSTRUCTIONS



PIONEER

The instructions covered herein also apply to Model PU-41A which is the PL-41A less the wooden base, and to Model PL-41C which is the Model PL-41A less the cartridge.

ASSEMBLY

NOTE: The turntable platter will be found under a cardboard sheet in the lower portion of the packing case.

1. REMOVE THREE MOTOR-BOARD CLAMPING SCREWS.

The clamping screws are tipped with red paint. When they are removed, the motor-board is freed from the base plate and supported by three suspension springs with plastic cushions. (Fig. 1)

2. LINE VOLTAGE AND LINE FREQUENCY

A. LINE VOLTAGE SELECTOR PLUG

The PL-41A is normally set for 240-volt operation prior to shipment. If the voltage in your area is 220, 130, 117, or 110 volts, pull out the line voltage selector plug and re-insert it so that the correct voltage reading appears in the cut provided in the selector plug. (Fig. 2)

B. CAPSTAN EXCHANGE

Two kinds of capstans are furnished with the Model PL-41A; one for 50-Hz operation and the other for 60-Hz operation. The 50-Hz capstan has a larger diameter, and the 60-Hz capstan, a smaller diameter with a groove in the lower part. The Model PL-41A is usually set for operation of the line frequency in the area to which it is shipped; however, if you move to some other area where the line frequency is different, you must change the capstan for proper turntable speeds. Find out the line frequency in your area and set the proper capstan in your turntable as follows: (Fig. 3)

- You will find a capstan set up on the motor shaft and a spare capstan laid on the base plate.
- Loosen two setscrews on the side of the capstan in use with the small screwdriver furnished in the accessory group, and remove them. Then pull out the capstan, from the motor shaft.
- Loosen the clamp that is holding the spare capstan, remove the capstan from the resting place, and install it on the motor shaft.
- Before tightening the setscrews, set the capstan in position on the motor shaft so that the center of the belt is aligned with that of the belt guide of the shift lever. (Fig. 4)
- Set the line frequency switch to the proper frequency position. (Fig. 3)

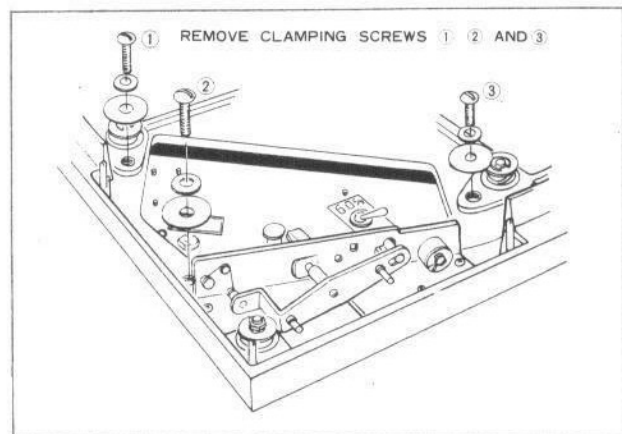

Fig. 1

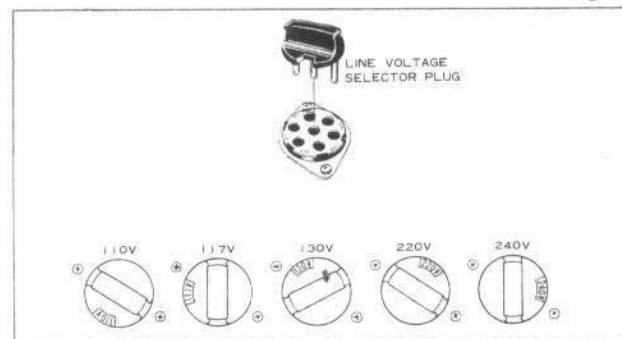

Fig. 2

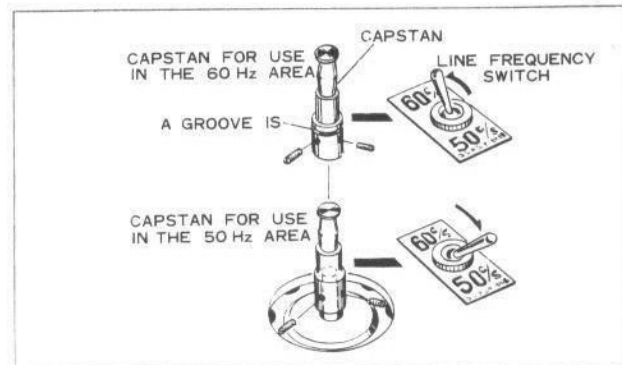

Fig. 3

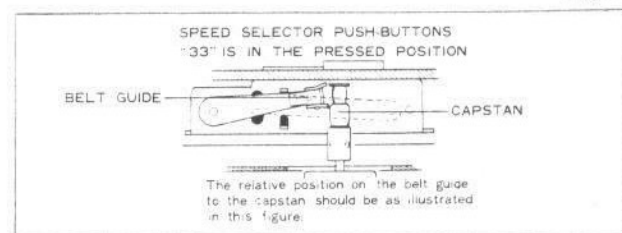

Fig. 4



3. MOUNT THE TURNTABLE PLATTER

Unpack the turntable platter and place it on the center shaft.
Place the two rubber mats on the platter.

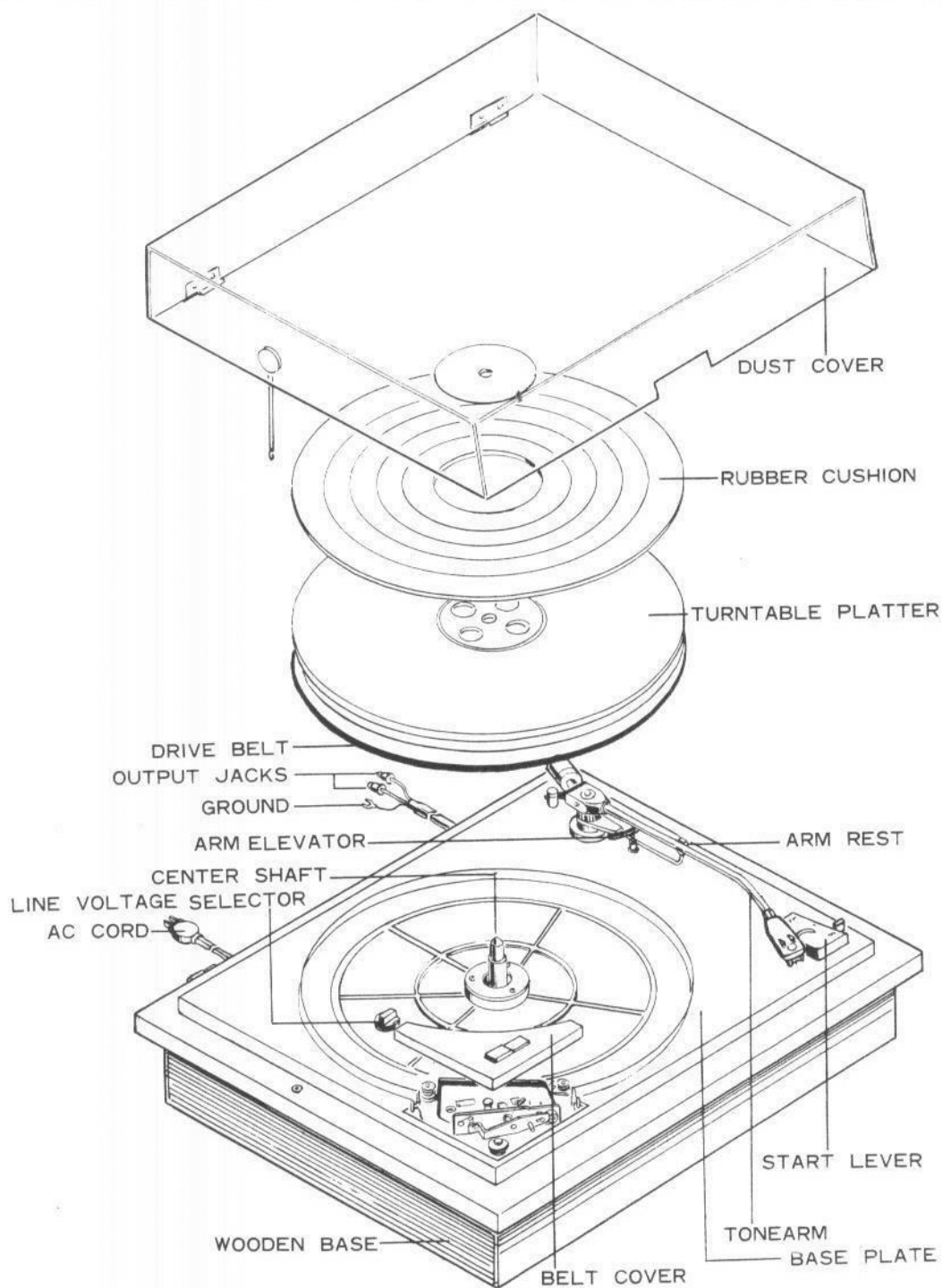

Fig. 5

4. SET THE BELT ON THE CAPSTAN

A short piece of ribbon is inserted under the belt for convenience in pulling the belt. Take out the belt cover (See Fig. 6) from the packing case and temporarily mount it over the belt drive mechanism area to see if the Belt guide is in the "33" (33-1/3 rpm) position. If not, press the "33" push-button. Remove the belt cover and put it aside for later use. Now, pulling the ribbon, set the belt around the smaller-diameter portion (for 33-1/3 rpm speed) of the capstan. After the belt is in its proper position, remove the ribbon. (Fig. 6)

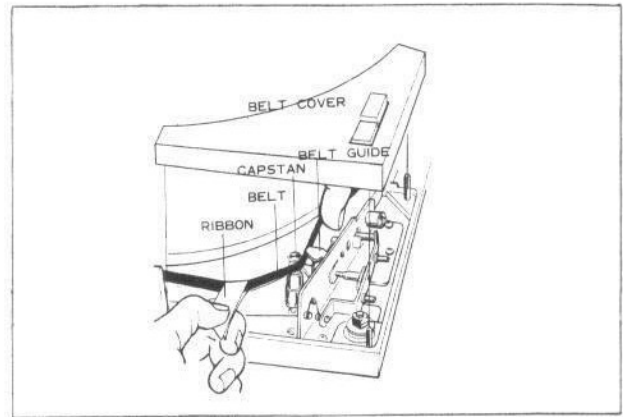

Fig. 6

5. ASSEMBLE AND INSTALL THE TONEARM

A. THE OUTPUT CORD IS TIED TO THE ARM ELEVATOR

Remove the output cord from the arm elevator and connect it to the plug connector provided in the bottom of the arm unit shaft. When inserting the cord connector into the plug connector, be sure that the key on the cord connector fits into the groove provided in the plug connector. (Fig. 8)

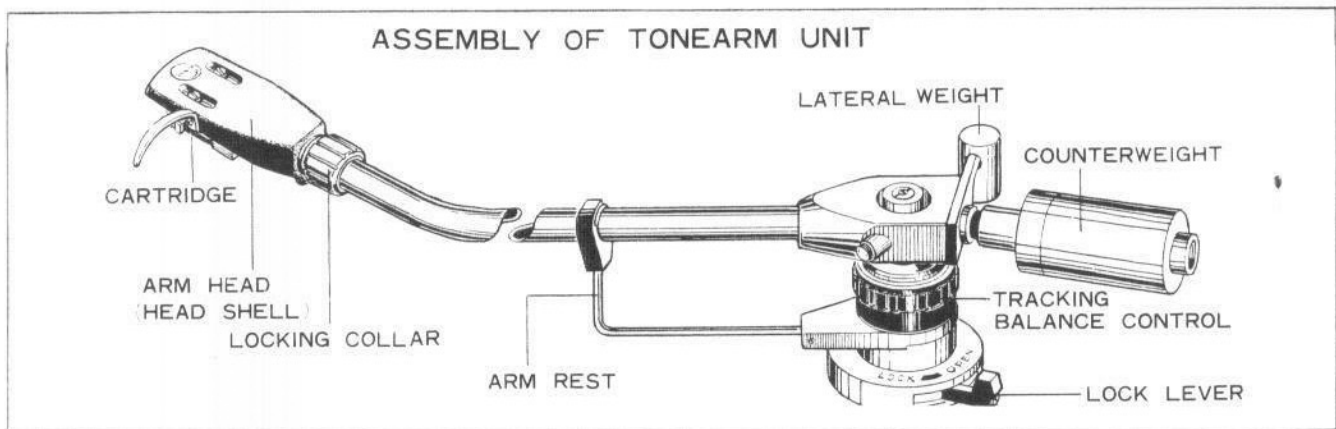

Fig. 7

B. MOUNT THE TONEARM

Set the arm unit shaft in the arm stand opening provided in the base plate, fitting the guide groove of the column against the projection inside the arm stand opening. Insert the support column as far as the red dot marked on the column, and lock it in position by moving the lock lever, located on the side of the arm stand, toward "LOCK".

When the height of the tonearm must be adjusted (When using a cartridge of a different size) set the lock lever to "OPEN" and adjust the height. (Fig. 8)

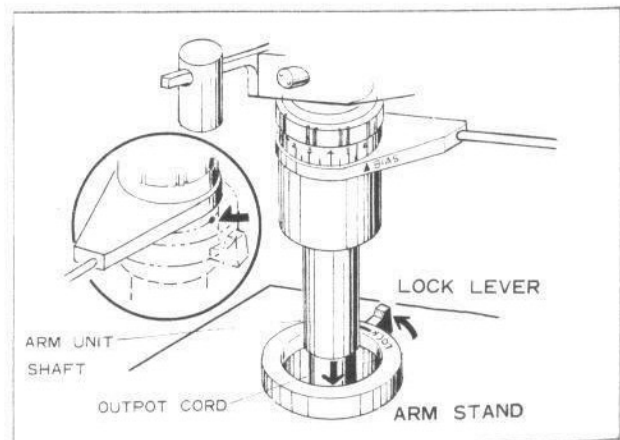

Fig. 8



C. ATTACH THE MAIN COUNTERWEIGHT

Attach the main counterweight onto the back of the tonearm. The threads of the counterweight and the arm will soon engage each other. Rotate the counterweight clockwise two or three turns. An auxiliary counterweight is supplied together with the main counterweight; however, it will not be required as long as the furnished cartridge, PC-35, is used. If another cartridge that weight more than 15 grams is to be used, mount the auxiliary counterweight on the back of the tonearm. (Fig. 9)

D. ATTACH THE ARM HEAD

Insert the arm head neck into the end of the arm pipe and tighten the locking collar. With the Model PL-41A, you can adjust the verticality of the stylus over a range of ± 2 to 3° . Holding the arm pipe tightly with one hand, turn the arm head with the other hand until the stylus becomes perfectly perpendicular to the record surface. (Fig. 10)

ADJUSTMENT

1. TONEARM BALANCING

Remove the stylus cover from the cartridge. With the tonearm off the arm rest, turn the main counterweight in either direction until the tonearm is horizontally balanced. A stylus pressure dial ring is provided at the front of the main counterweight. While keeping the main counterweight in position, turn the dial ring until the 0-gram reading on the dial aligns with the black index line engraved on the tonearm. The stylus pressure is now zero grams.

2. LATERAL BALANCE ADJUSTMENT

After the tonearm is balanced, set the "0" reading on the tracking balance control dial to the bias INDEX mark engraved in the arm unit support column. Raise the rear of the turntable base until its bottom makes an angle of about 20 degrees with respect to the horizontal plane, and see if the tonearm drifts in either direction. (Fig. 12) If the tonearm tends to drift toward the center of the turntable (to the left when viewed from the front), inch the lateral balancing weight toward "A" in Fig. 12, and if it tends to drift toward the outside (to the right when viewed from the front), inch the lateral balancing weight toward "B". Repeat this adjustment until the tonearm completely balances laterally. (Fig. 12)

NOTES • Since a permanent magnet is used in the tracking balance control, its magnetic field always tends to make the tonearm drift toward the outside of the turntable. Therefore, the tonearm may drift toward the outside of the turntable even if the tracking balance control is set to zero and the lateral balancing is perfect.

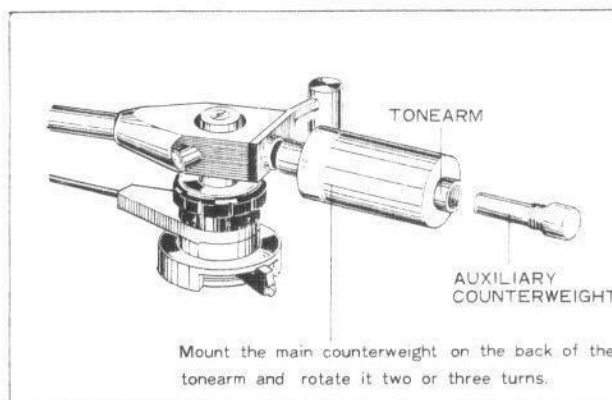

Fig. 9

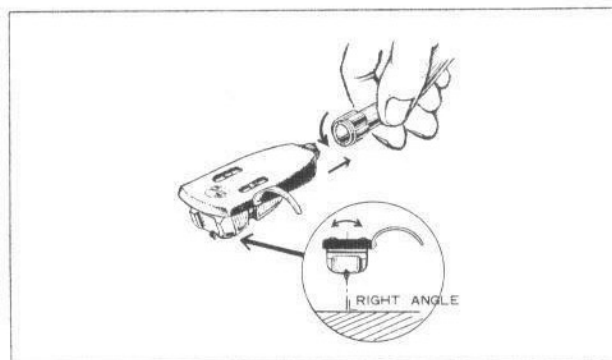

Fig. 10

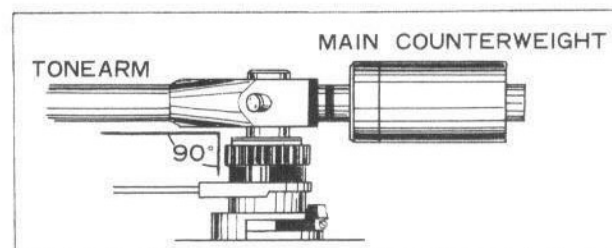

Fig. 11

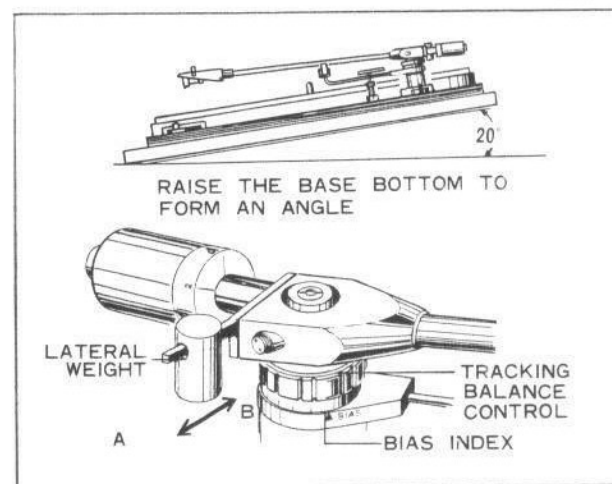

Fig. 12

- Adjustment for lateral balancing is usually made with the stylus cover removed. Extreme care must be paid not to drop the arm head on the platter or turntable base plate.

3. TRACKING FORCE (STYLUS PRESSURE) ADJUSTMENT

After lateral balancing is adjusted, turn the main counterweight together with the stylus pressure dial ring (the dial is direct-reading up to 4 grams in 0.5 increments). Set the stylus pressure 2~3 grams position which is optimum for the PC-35.

4. TRACKING BALANCE ADJUSTMENT

When the turntable is rotating, the stylus mounted in an angled tonearm head tends to run toward the center of the record. This is caused by friction between stylus and rotating record, and deflects the stylus against the inner groove wall and away from the outer wall. The force which produces such tendency is called "skating force". The skating phenomenon is undesirable because it introduces distortion. In general, the magnitude of skating force is about 10% of the stylus pressure. The Model PL-41A cancels this harmful skating force with a very simple provision. The relation between optimum settings of the tracking balance control and stylus pressure values on the PL-41A is illustrated in Fig. 13. When a desired stylus pressure is determined and set on the Model PL-41A, find the optimum setting of the tracking balance control from the curve shown in Fig. 13, using the pressure value, and rotate the tracking balance control until the value found from the curve comes above the BIAS mark. (Fig. 14)

For example, if the stylus pressure is 2.5 grams, the optimum setting of the tracking balance control will be about 8.5 as illustrated in Fig. 13. In this instance, bring "8.5" on the tracking balance control above the BIAS mark as shown in Fig. 14.

NOTE: The balance of the stylus in the groove may be affected when the stylus or the record is changed, although the tracking balance control is properly adjusted initially; however, the influence on music reproduction is practically negligible.

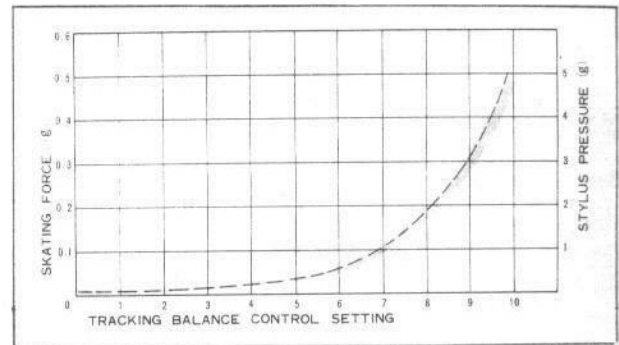

Fig. 13

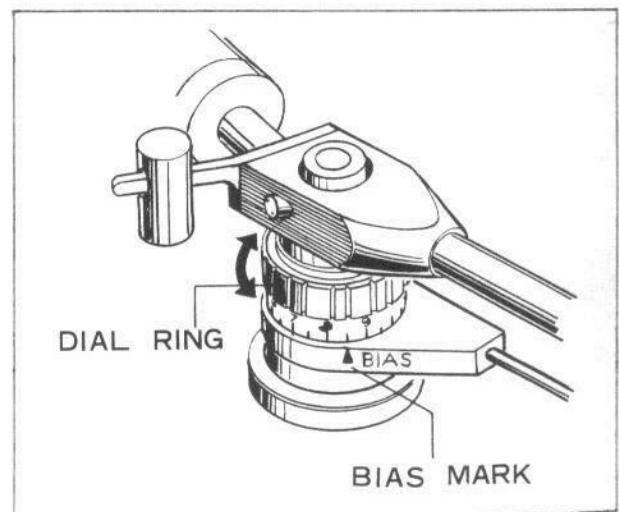

Fig. 14



FUNCTIONS OF CONTROLS

1. SPEED SELECTOR PUSH-BUTTONS

The PL-41A is a two-speed model: 33-1/3 rpm and 45 rpm. Two push-buttons provided on the belt cover control selection of speeds. Pressing the desired speed push-button will automatically set the turntable for operation of the speed marked on the push-button. The PL-41A is a belt drive system in which the motor drives the turntable platter through a belt. Therefore, changing turntable speeds must be done only when the turntable platter is rotating. (Fig. 15)

2. START LEVER

The start lever has three control positions; "OFF", "ON", and "DOWN". The lever is used to turn the motor on and off and to raise and lower the tonearm. The turntable operation for each lever position is: (Fig. 16)

ON Bringing the lever from OFF to ON will raise the tonearm and apply power to the motor, causing the turntable to start rotating. If the lever is brought from DOWN to ON while the record disc being played, the arm head will quietly float up from the record surface. This eliminates the danger of dropping the arm head on the record.

DOWN After the tonearm is raised, the arm head should be brought above the cueing position. Then, bringing the lever to DOWN will cause the head to float down quietly with the stylus point landing in the cueing groove.

OFF Bringing the lever from ON to OFF will remove power from the motor. If the lever is brought from DOWN to OFF directly, the tonearm will float up and stay there while the motor is shut off. Be sure that the lever is brought to OFF after using the PL-41A.

3. TONEARM ELEVATOR

As mentioned in the preceding paragraph, the tonearm is raised or lowered with the start lever. This operation is accomplished by the tonearm elevator shown in Fig. 17. The travelling stroke of the tonearm can be adjusted by loosening the lock nut. (Fig. 17)

4. ARM REST AND 45-RPM ADAPTER

The arm rest supports the tonearm in place when the tonearm is not in use. A clamp is provided on the arm rest. It is a good practice to keep the tonearm in the clamp except when the Model PL-41A is in use.

A 45-rpm adapter is supplied in the accessory group, which permits 45-rpm records to be placed on the PL-41A.

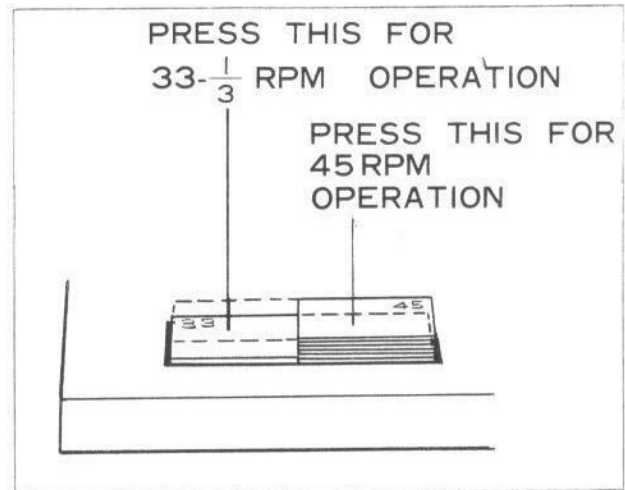

Fig. 15

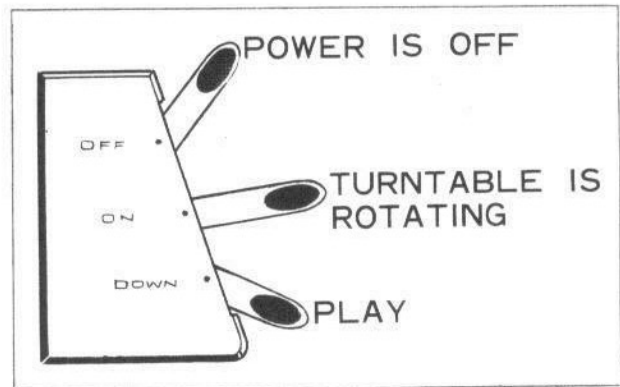

Fig. 16

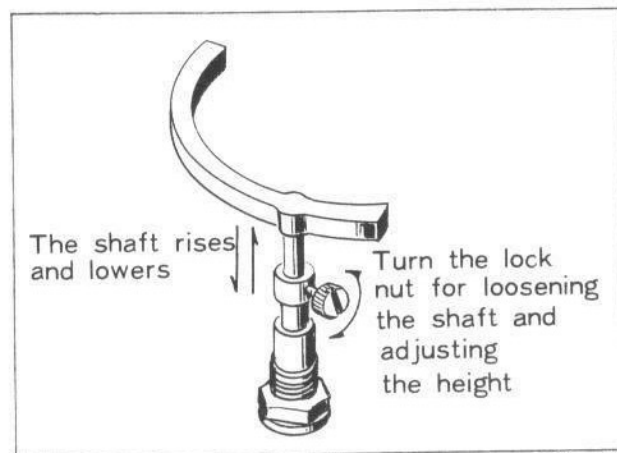

Fig. 17

CONNECTION TO A STEREO AMPLIFIER

- The furnished cartridge, PC-35, is an induced magnet type cartridge. Therefore, use the MAG input jacks of your amplifier for connection to the cartridge.
- The output cord of the PL-41A has three leads at its end; the first (white) is marked with "L", the second (red), "R", and the third is black with no letter.
- The "L" lead has a pin plug for connection to the left channel input jack on your amplifier, and the "R" lead, a similar pin plug for connection to the right channel input jack. The black lead has a terminal lug for connection to the grounding terminal on your amplifier. (Fig. 18)

OPERATING OF PL-41A

The Model PL-41A is designed specifically for ease of operation. Follow the steps described below:

- (1) Place the record on the turntable platter.
- (2) If the stylus cover is still on the cartridge, remove it.
- (3) Set the start lever to ON; the turntable will begin rotating.
- (4) Press the desired speed push-button.
- (5) Move the tonearm by hand and bring the arm head above the cuing position.
- (6) Move the start lever from ON to DOWN. The tonearm will quietly float down until the stylus gently fits in the cuing groove. The music starts.
- (7) When the record is over, set the lever to OFF and bring the tonearm back onto the arm rest. If the turntable is not used for a while, clamp the tonearm to the arm rest.
- (8) Another way to operate the turntable.

When you play an LP record, you may desire to listen to only specific portions of the record. In this case, you can set the tonearm position by hand without turning the motor off by maneuvering the start lever only between DOWN and ON.

1. STYLUS REPLACEMENT

The furnished cartridge, PC-35, uses a diamond stylus, PN-35. This stylus should last for about 400 to 600 hours of operation. For record protection, it is recommended to replace it before it wears out completely. Replace the stylus as follows: disconnect the arm head from the tonearm pipe. The stylus is held in position in a plastic holder. Pull out the plastic holder with the stylus, diagonally. Replace the stylus with a new one and put the holder back into the cartridge. When purchasing a replacement stylus, specify PN-35. (Fig. 19)

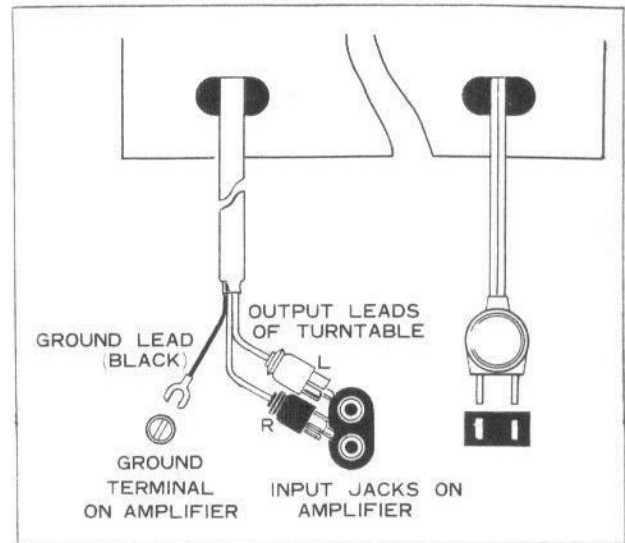

Fig. 18

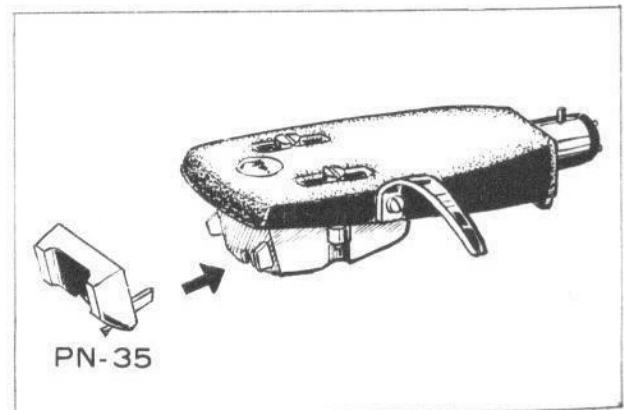

Fig. 19



2. CHANGING THE CARTRIDGE

If you want to use a cartridge of a different type, use the furnished spare head shell. Fig. 20 illustrates the mounting procedure. In this case, particular care must be paid to the connection of the cartridge output leads to those extending from the shell neck.

Two cartridge mounting screws are also furnished in the accessory group. First, mount the cartridge loosely with these screws, align the stylus point with the stylus position registering holes provided in the shell, and then tighten the mounting screws securely.

If the cartridge is lighter than 8 grams (0.28 oz), add the supplementary weight plate (furnished in the accessory group) between the head shell and the cartridge. If the cartridge is heavier than 15 grams (0.53 oz), mount the auxiliary counterweight (also furnished in the accessory group) in the back of the tonearm. In either case, tonearm balancing (horizontal, lateral, and tracking balances) must be readjusted. (Fig. 20, Fig. 21)

OPERATING CONSIDERATIONS

1. CHANGE TURNTABLE SPEED ONLY WHEN THE TURNTABLE IS ROTATING

In the belt drive system, the turntable speed is changed by shifting the belt up or down on the step capstan by a lever that is controlled with the speed selector push-buttons. For this reason, when the speed is to be changed, the turntable must be rotating to facilitate shifting of the belt. An attempt to change the speed forcibly by pressing a push-button while the turntable is stationary may damage the belt. (In other words, the start lever must always be in the ON position whenever the speed is changed.)

2. DO NOT HOLD THE ROTATING TURNTABLE BY HAND.

Holding the rotating turntable by hand may cause the belt to go out of the track.

3. BE CAREFUL OF SHOCK OR VIBRATION

The Model PL-41A operates with a very small tracking force. Select the location of the PL-41A with care. It should be in a stable position. It is a good practice to keep the unit away from the loudspeaker cabinets as far as possible.

4. ALWAYS KEEP THE STYLUS CLEAN

Dust collected on the stylus point degrades the quality of reproduced sound. If dust is found on the record surface, remove it with a soft, clean cloth dampened with a commercially available record cleaner. When cleaning the stylus, care must be exercised not to touch the stylus with fingers.

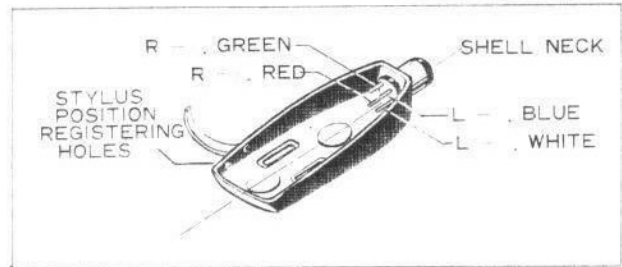

Fig. 20

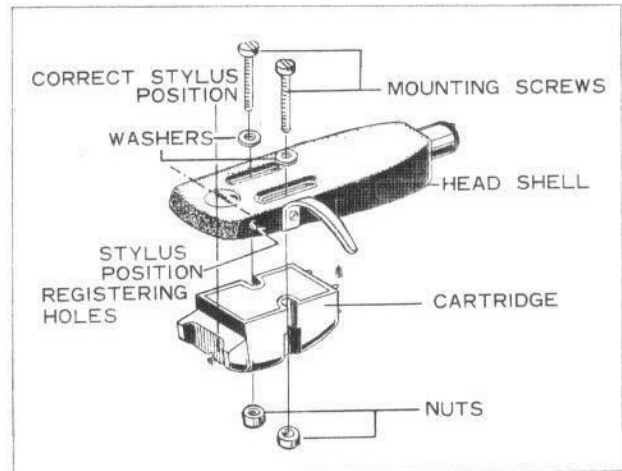

Fig. 21

5. HUM

Hum is a low-pitched droning noise, often 60 or 50 Hz, resulting from a loose connection of the ground lead. If hum occurs:

- Check the connection of the PL-41A ground lead (the black lead with a terminal lug) to your amplifier. If loose or not connected at all, correct the connection.
- Check to see if the output cord of the PL-41A is running near the power transformer of your amplifier. Changing the relation of the PL-41A and the amplifier will often eliminate hum.

6. BUZZ

"Buzz" is a relatively high-pitched noise resulting from induction due to exposure to high intensity TV signals. In this case the pickup cord is functioning as an antenna for picking up the TV signals. If buzz occurs, either make the tonearm cord shorter or change the relation between the turntable and the amplifier.

7. HOWLING

"Howling" is acoustical feedback from loudspeakers to the tonearm or cartridge. Increasing the distance between the loudspeakers and the turntable, or even better, laying a soft cushion underneath the turntable base will eliminate howling.

LUBRICATION

Mechanical noises, and wow and flutter usually result from insufficient lubrication in rotating parts. In some instances, lack of lubricant may cause the motor to freeze or to burn its windings. Be sure that you lubricate the specified points at least once every two months if the PL-41A is used for home entertainment, and two to three times a month if used for professional purposes.

One lubricating point is shown in Fig. 22 (lubricating hole). Another lubricating point is the center shaft of the turntable platter. Remove the platter and lubricate the shaft with two or three drops of oil at the same time you lubricate the lubricating hole. In this case, make sure not to let oil adhere to the belt or capstan. If oil gets on the belt or capstan, remove it with a cloth dampened with alcohol.

TROUBLE SHOOTING

1. TURNTABLE SPEED IS IRREGULAR

In most cases, irregular turntable speed results from lack of lubricating oil in the bearing of the turntable shaft. If irregular speed is noticed, remove the bottom cover, unscrew the bearing cap on the bottom end of the platter shaft, pull out the shaft, wipe off the used oil with a soft cloth, put the shaft and cover back, and apply several drops of oil to the shaft from the platter side. For lubrication, use the furnished oil or its equivalent.

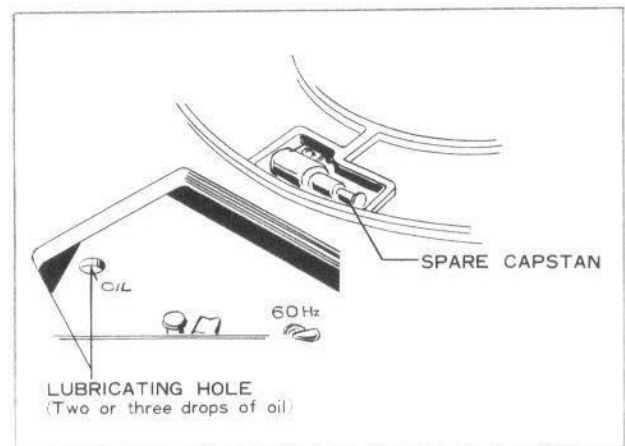

Fig. 22



2. WOW AND FLUTTER

Wow and flutter usually result from oil on the capstan or belt. Check the surfaces of the capstan and belt, and if oil is found wipe it clean with a soft cloth dampened with alcohol.

CAUTION:

Never use other solvents.

SPECIFICATIONS

Model PL-41C is the model PL-41A less the cartridge. Model PU-41A is the model PL-41A less the wooden base.

Turntable drive	2-speed, belt-driven system
Motor	4-pole, hysteresis synchronous type
Turntable Platter	31 cm 12 $\frac{1}{4}$ " in diameter, aluminum alloy diecast, 4 lb 7/8 oz 2.2 kg
Wow and flutter	Less than 0.08%
SN ratio	More than 50 dB
Tonearm	Static balance type
Cartridge	PC-35 (Induced Magnet type)
Stylus	PN-35 (Diamond 0.5 mil)
Frequency Response	10 ~ 25000 Hz
Channel Separation	More than 25 dB/1000 Hz
Output Voltage	3.5 mv 1000 Hz 50mm/sec
Load Resistance	30 ~ 100 k Ω
Compliance	10 x 10 ⁻⁶ cm/dyne (100 Hz)
Stylus Pressure	2 ~ 3 g
Power requirement	110, 117, 130, 220, or 240 V, 50 or 60 Hz
Power Consumption	29 VA (maximum)
Dimensions	19 11/16" (W) 7 11/16" (H) 15 15/16" (D) 500(W) x 195(H) x 405(D) mm

NOTE: Specifications and the design may be subject to modification without notice.